



## For your safety

### WARNING! Your engine is not a toy!

- You will be working with highly flammable fuel, so keep it away from exposed flames or anything which might ignite it. Read the safety info on the fuel container.
- Do not use fuels that were not designed for R/C Car glow plug engines.
- Keep the fuel out of reach of children!
- Deadly carbon monoxide gas will be released, so do not operate the engine in an enclosed area where exposed flames or sparks can ignite it, or where it causes you to inhale it for prolonged periods.
- During operation, the engine may be dangerously hot to the touch.
- Do not use the engine for purposes other than in model cars designed for them.
- Mount the engine securely.

# 1 Introduction

Thank you for purchasing this Team Associated engine. This manual contains the instructions needed to operate and maintain your new engine. Please read this manual completely to obtain maximum performance and reliability from your new Team Associated engine. Pay special attention to the break-in instructions outlined in this manual. The engine must be broken in to achieve maximum performance. Follow the directions in this manual exactly.

Your engine manual is divided into seven parts:

- PART 1 Introduction
- PART 2 How to set the carburetor and start your engine
- PART 3 Breaking in your engine for the first time
- PART 4 Tuning your engine's performance
- PART 5 Care and maintenance
- PART 6 Troubleshooting your engine
- PART 7 Catalog information

### Required Equipment

- Glow plug starter
- Model car fuel
- Fuel bottle
- Small Phillips head and flat head screwdriver
- Spare glow plugs
- Foam prefilter oil treatment
- 5/16 nut driver or a glow plug wrench

### Glow plug starter



**Glow Plug Starter** The glow plug starter is a battery powered device used to heat up the glow plug so the motor will start up. Once the motor starts, the glow plug starter will be removed.

**Model Car Fuel** The proper fuel is very important for long engine life. Improper fuel can cause hard starting, poor performance, and excessive wear of the components of the engine. The fuels we recommend for R/C car use are:

- O'Donnell Racing Fuel
- Duratrax Red Alert Fuel
- Blue Thunder Race Formula
- Wildcat Fuels
- Trinity
- Byron's Originals
- Traxxas Top Fuel.

There are many racing fuels available, however they must meet some requirements:

1. The fuel must contain both castor and synthetic oils.
2. You should try to keep the nitro (nitromethane) content between 15% to 30%.

The best fuels also contain rust and corrosion inhibitors, anti wear agents, anti foaming agents and lubrication additives. **IMPORTANT:** DO NOT use any type of airplane fuels. Airplane fuels may not have the necessary oil types and ratios needed for R/C cars.

**Fuel Bottle** For conveniently filling the tank, use a smaller fuel bottle with a dispensing tube and cap to prevent the fuel from evaporating or getting contaminated.

### Fuel bottle



AE Part #1749

### Glow plug



**Glow Plug** The purpose of the glow plug is to ignite the fuel in the engine. We recommend using the #MC59 McCoy or the ODO99 O'Donnell glow plugs.

# 2 How to set the carburetor and start the engine

## BEFORE STARTING THE ENGINE

The first start-up of your engine is the most critical moment of the engine's life, dictating how it will perform from this time forward.

### Step 1 Oiling the filter.

The air filter is essential for keeping dirt out of the engine. The air foam filter must be oiled before running the engine. We recommend using Associated #7710 foam pre-filter treatment. Dab the treatment all around the filter, put the filter in a plastic bag and knead it until the filter is saturated, but not soaked.

**Never run your vehicle without the air filter.**

### Step 1



### Step 2

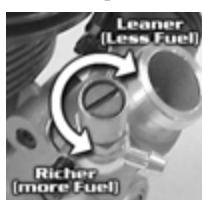

High Speed Mixture:  
2 3/4 turns out

### Step 3



Low Speed Mixture:  
6 1/2 turns out

### Step 4



Idle Speed: .020" opening (.5mm).  
Larger opening = higher idle speed.  
Smaller opening = lower idle speed.

### Step 2 Setting the high-speed mixture.

The high-speed mixture screw controls how much fuel enters the engine during mid- to high-speed operation. Screw the high-speed mixture screw clockwise gently until it stops. DO NOT over tighten. Now turn the mixture screw counter-clockwise 2 3/4 turns.

### Step 3 Setting the low speed.

This screw meters the fuel at low speeds. The low-speed mixture screw is located in the end of the carburetor. This screw controls how much fuel enters the engine at idle and low throttle. This adjustment will smooth the idle and improve the acceleration to mid speed. Make this adjustment with the throttle closed, after setting the idle. Turn the screw clockwise gently until it stops. DO NOT over tighten. Now turn the low-speed mixture screw counter-clockwise 6 1/2 turns.

### Step 4 Setting the idle speed.

The idle screw regulates the throttle opening to control the idle speed. The throttle opening at idle should be set as shown in the picture below. Turn the screw until the throttle opening inside the throttle valve is .020" (.5mm). The idle speed may need to be readjusted after the engine is warm.

### Step 5 Putting fuel in the fuel tank.

Squeeze the empty fuel bottle, put the bottle's tube into your fuel container, and draw out some fuel. Lift up the lid on the fuel tank, and slowly squeeze the fuel bottle until the tank is full. Be careful. If the tank overflows it might get on your radio gear or on your brakes and you may create an unsafe driving situation. Always keep your fuel bottle closed when not in use.

## HOW TO START THE ENGINE

### Step 1

**To STOP the engine**, pinch and hold the carburetor's fuel line while running at idle speed. DO NOT shut off the engine by placing your finger over the exhaust pipe. Another way is to push a piece of wood (or plastic handle of a tool) firmly against the flywheel.

**Step 2** Turn on your radio system and attach a glow starter to the glow plug.

**Step 3** Start the engine with your pull starter.

*For pull start engines, note the following tips:* Never pull the rope out to its full length; doing so can cause damage and the rope may not retract. Quick, short pulls of the pull start rope are the best technique to use with a pull starter. DO NOT extend the rope more than 12" (305 mm).

Do not abruptly release the handle. Allow the cord to rewind smoothly while still holding the handle. Pull the operating handle straight out when starting the engine, so that the cord does not rub against the vehicle's body or engine. This will help prevent the cord from being damaged by abrasion or engine heat. Try to avoid spilling fuel over the starter unit and its cord. Some fuels have a damaging effect on these parts.

If the pull starter is very hard to pull (it will not extend out of the pull starter assembly), the engine may be fuel-locked. Excessive fuel between the head and the piston will not let the piston move through its proper range of motion. To fix, loosen the glow plug one turn and try to start the engine. If the engine starts, tighten the glow plug with the glow plug starter while the engine is running.

If the engine still will not start, there could be a problem with the glow plug, glow starter or the engine could be flooded. Refer to the trouble-shooting guide later in this manual.

# 3 Breaking in your engine for the first time

## Read this before you drive

The key to breaking in your engine is patience. During the break in period, your engine may appear to malfunction with problems such as stalling, inconsistent performance, and fouling glow plugs. Don't give up. These are just a few things you may go through during the break in period. Just keep it running, apply the throttle on and off as smoothly as you can. Sudden bursts or quick releases of the throttle can stall your engine. Soon after break in your patience will pay off with a well running engine.

During break in, use the fuel with the same percentage of nitro which you plan to run every day. The performance level of the engine will be limited by the "rich" fuel mixture which you will use all during the break-in process. Once the engine is fully broken-in the mixture can be "leaned," and speed and acceleration will increase. Because of the rich fuel mixture and the wearing of the new parts, deposits will form on the glow plug causing it to fail. Expect to replace the glow plug during the break in period, and definitely when the engine is fully broken in and the fuel mixture is leaned.

## Understanding the engine terms "rich" and "lean"

Your carburetor has adjustment screws that regulate how much air and fuel enter the engine together (air/fuel mixture). An air/fuel mixture that is too "rich" means there is too much fuel, and a mixture that is too "lean" means that there is not enough fuel for the given amount of air.

When the mixture is too rich, performance will be sluggish (one symptom of this is excessive amount of smoke from the exhaust). There is also a potential to foul the glow plug when the mixture is too rich.

When the mixture is too lean, there is not enough fuel to cool or lubricate the internal engine components, and damage to the engine and/or glow plug is almost certain.

Turn the high-speed mixture screw **clockwise** to lean the mixture. This decreases fuel flow for given amount of air. Turn **counter-clockwise** to richen the mixture and increase the amount of fuel to be mixed with the air.

**Caution:** If, while you are driving, the engine stalls because of an overheating condition, severe damage may have already occurred. Overheating is caused by the following conditions.

- Fuel mixture is set too lean.
- Air leak around carb.
- No air filter.
- Loss of muffler pressure (line falls off).
- Excessive nitro content in the fuel.
- Incorrect oil content in the fuel.
- Poor quality of fuel.
- Contaminated fuel.
- Excessive loads on the engine (binding in drive train)

Your engine will be short-lived if any of the above conditions are allowed to exist for any length of time.

During tanks one to four watch closely for any signs of overheating. These will include:

- Steam or smoke coming from the engine surfaces
- Very high engine speeds during acceleration, as if it is running out of fuel.
- Popping or clattering sound when slowing down.
- Idle speed will surge or possibly diminish to the point of stalling.

## To Test For Overheating:

It's important to check the head temperature during the operation of the engine. The best method for checking the head temperature is to use a head temperature gauge. There are several head temperature gauges available, and the temperature readings between these different brands of gauges vary. Due to this variance, the proper temperature readings will range between approximately 220 degrees and 260 degrees. If you don't have access to a head temperature gauge, you can use water to

check the head temperature. Place a drop of water on top of the cylinder head. If it sizzles away immediately, shut down your engine. If it takes approximately 3-5 seconds for the water drop to boil away, then the engine is running within a normal temperature range.

## The First Two Tanks of Fuel

**Step 1** The high-speed and low-speed mixture screws should already be set as they were described to you earlier in this manual, Part 2, Step 3, "Setting the high-speed mixture," and Part 2, Step 4, "Setting the low-speed."

However, for break in procedures, the engine should run richer than these settings. Turn the high-speed mixture screw counter-clockwise 1/4 turn from the position you set it earlier to run it richer.

**Step 2** Start your engine. Once the engine is started, ease in and out of the throttle slowly to warm the engine. If the engine keeps stalling when accelerating, then richen the high-speed mixture screw a 1/8 of a turn counterclockwise.

The idle speed should be set as fast as possible without causing the vehicle to move. If necessary, adjust the idle screw as described to you earlier in Part 2, Step 5, "Setting the idle speed."

**Step 3** The standard setting of the high-speed mixture screw will vary slightly with each engine. To know if your engine is set correctly you will find the following performance characteristics (on a warmed up engine):

The engine will accelerate sluggishly from a standing start and may even try to quit if the throttle is applied too quickly.

Blue-white smoke will be coming from the exhaust.

When the car is accelerating at full throttle, the engine will never "Clean Out". When an engine cleans out, the speed and the rpms will increase suddenly and dramatically. Also, the amount of smoke that comes from the exhaust will decrease. Cleaning Out is a desirable characteristic once the engine is fully broken in.

As the engine reaches normal operating temperature, it will speed up and performance will increase. This occurs because the fuel mixture is becoming leaner with the increased temperature. You will need to richen the fuel mixture about 1/16 of a turn or more so that the engine continues to run as described above.

**Step 4** When the first tank is almost gone, bring the car in and shut off the engine. Allow the engine to cool for 8 to 10 minutes before starting the engine up again. Add more fuel. Start it back up and run the second tank of fuel. Again allow the engine to cool before starting it up again.

## Tanks Three – Four

**Step 5** Turn the high-speed mixture screw clockwise (leaner) 1/8 of a turn and run it through the third tank of fuel. Repeat this step for the fourth tank of fuel. This completes the engine break-in procedure. Now go on to Part 4, Tuning.

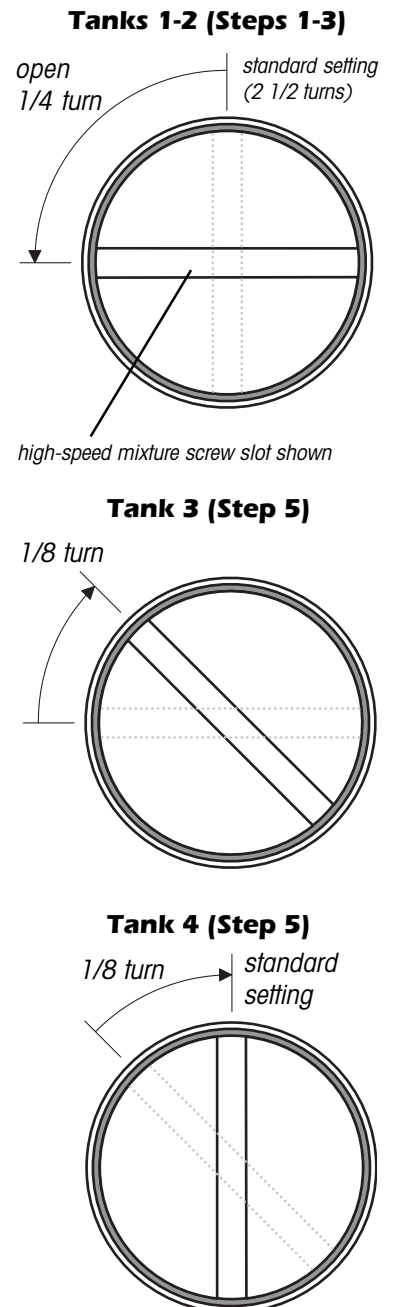

# 4 Tuning your engine's performance

## TUNING THE ENGINE FOR MAX POWER:

Sometime between the fourth and the sixth tank of fuel, the inner engine parts should be settled and broken in. You can then begin adjusting the fuel mixture to maximize performance for your driving needs.

As you continue to lean the fuel mixture, the engine will run faster up to a point. When the engine is set too lean, it will seem to run strong at first, but will bog, hesitate, or stall when running at high speed. The engine will also rapidly overheat when the setting is too lean. This is because fuel includes lubrication, and that lubrication is inadequate when the setting is too lean.

CHECK THE ENGINE TEMPERATURE OFTEN AS YOU LEAN THE MIXTURE. DO NOT LET THE ENGINE OVERHEAT. You should always see smoke coming from the exhaust.

At the optimum setting, the engine will clean out; have a strong-sounding, high-pitched whine at full speed; and there will be a thin trail of whitish smoke coming from the exhaust. It is always better to set the engine a little rich rather than too lean.

Find an area with a long straight-away so you can allow the en-

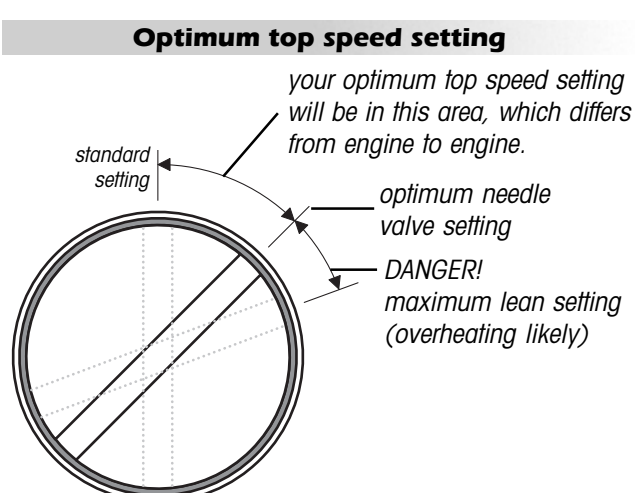

gine to run at full speed. Run your car two or three passes at full throttle and note its performance. Turn the high-speed mixture screw clockwise 1/8 of a turn and retest your car, again noting the vehicle's performance. Continue to lean the mixture and retest the vehicle until the highest speed is achieved. At that point, turn the mixture screw counterclockwise 1/16 of a turn. This is the optimum setting that the engine should be set to run at.

If the engine stalls on acceleration, begins to bog or slow down at full throttle, or if there is a reduction in exhaust smoke, then the engine is running too lean. Immediately turn the high speed mixture screw counterclockwise 1/4 of a turn and operate the car at medium speeds for 1 to 2 minutes to allow the engine to cool, then continue testing.

## TUNING FOR LOW-SPEED PERFORMANCE

The low-speed mixture affects how the engine will perform in the low to mid range rpms. Turning the low-speed needle clockwise will lean the mixture. As with the high-speed mixture, leaning the low-speed mixture increases performance. Again, if the mixture is set too lean, the engine may be starved for lubrication in the low and mid-rpm ranges, thus causing overheating and excessive engine wear.

Perform the following test to determine if the low speed mixture is set correctly. With the engine warm and running, allow it to idle for approximately 15 seconds. Now quickly apply throttle and note the performance.

If the engine bogs, accelerates erratically, and a large puff of blue smokes emitted, then the low speed mixture is too rich. Turn the low-speed screw clockwise 1/8 of a turn.

If the engine speeds up for a moment then bogs, hesitates, or stalls, then the low speed mixture is too lean. Turn the screw counterclockwise 1/8 of a turn. Adjust the mixture screws in 1/8 of a turn increments, wait 15 seconds, and retest after each change. Adjust for the best acceleration without the car stalling.

# 5

## Care and maintenance

### CARE AND MAINTENANCE

When you are finished racing for the day, drain the fuel tank. Afterwards, energize the glow plug with your glow plug starter and try to restart the engine in order to burn off any fuel that may remain inside the engine. Repeat this procedure until the engine fails to fire. Try to eject residue while the engine is still warm.

Finally, inject some corrosion inhibiting oil (After-Run Oil), and rotate the engine to distribute the oil to all the working parts. Do not, however, inject the oil into the carburetor, for it may cause the O-rings inside to deteriorate.

When cleaning the exterior of the engine, use Nitro-Clean. Do not use gasoline or any solvents that might damage the silicone fuel tubing.

### Cleaning the air filter

When the air filter starts to get dirty, do the following steps.

**Step 1** Clean the foam with dish soap & water. When it looks cleaner, dry the filter with a towel & let the filter dry completely before oiling.

**Step 2** Apply Associated's #7710 Foam Pre-Filter Treatment to help keep the dirt out. Dab a small amount of treatment all around the filter, put the filter in a plastic sandwich bag, and knead it until the filter is saturated, but not soaked.

### Foam Pre-filter Treatment



AE Part #7710

# 6

## Troubleshooting your engine

**Glow Plug Problems** The glow plug in your engine is an inexpensive consumable item which must be replaced periodically to maintain peak performance and starting ease. Most often, any starting problems or erratic performance can be traced back to the glow plug. The glow plug should also be checked if the engine's acceleration and top speed performance suddenly becomes flat.

The only sure way to test for a faulty glow plug is simply install a new one to see if the problem goes away. Remove the plug from the cylinder head with a 5/16" nut driver. Make sure there is no dirt or debris on top of the head which could fall into the engine. Do not lose the copper gasket which seals the glow plug. Touch the glow plug to the contacts of the glow plug starter. All of the coils should glow white. Sometimes the first few coils will not glow while the rest are bright, most likely indicating a bad plug. If the glow is dim orange, then the glow starter battery should be replaced or recharged.

**Flooding** You may accidentally flood the engine at some time, sometimes caused by squeezing the primer bulb to many times. Symptoms of a flooded engine include difficulty starting and muffled sounds coming from the exhaust. Remove the glow plug with a 5/16" nut driver and then remove the air filter. Turn the engine upside down to drain any excess fuel out of the combustion chamber and carburetor. Turn the vehicle back over and install the glow plug. The engine should start and run normally.

**Fuel Mixture** The fuel mixture is the largest variable you have to control while operating your engine. Fuel brand, ambient temperature, and humidity all effect how your mixture should be set. If the engine runs great one day but runs rich or lean the next day, it is probably the result of a change in the air quality and temperature. This should be expected and adjusted for.

**Cooling Problems** Engine overheating is most often caused by running the engine too lean or because the cooling air for the cylinder head is blocked. If the mixture is too lean, simply allow the engine to cool, richen the mixture and try it again. Bodies must have holes cut in them to allow for cooling air to circulate over the surface of the cylinder head. On most bodies, it is a good idea to cut part of the windshield out and part of the back window to allow for additional cooling.

Troubleshooting Chart

Description	Problem	Solution
Engine will not start	Out of fuel	Fill fuel tank
	Improper or contaminated fuel	Replace fuel
	Glow starter not charged	Charge glow starter
	Glow plug bad	Replace glow plug, see "Glow Plug Problems" section.
	Engine flooded	See "flooding" section.
	Engine overheating	Allow engine to cool, richen fuel mixture, check airflow
	Carburetor incorrectly adjusted	Re-adjust carburetor
	Exhaust blocked	Clean exhaust system
	Air cleaner blocked	Clean air filter
Starter will not pull	Engine is flooded	Clear excess fuel, see "flooding" Section.
	Rope is jammed	Repair starter.
	Engine seized	Examine engine for damage.
Engine starts and then stalls	Idle speed set too low	Increase idle speed.
	Air bubbles in fuel line	Check for holes in the fuel line.
	Glow plug is fouled	Replace glow plug, see "Glow Plug Problem" section.
	Engine is overheated	Allow engine to cool, richen fuel Mixture, check airflow
	Insufficient fuel tank pressure	Replace pressure hose- clear
	Blockage at exhaust header fitting	Check flow to and from the tank.
Engine sluggish / poor performance	High-speed fuel mixture is too rich	Set high-speed mixture to a leaner setting
	Leaking glow plug	Check glow plug gasket
	Fuel bad or contaminated	Replace fuel
	Carburetor dirty or blocked	Clean Carburetor
	Engine overheating	Stop the engine- find the cause
	Engine over geared for application	Use a lower gear ratio
	Clutch slipping	Replace clutch shoes
	Bound up drive train	Find the bound item and repair
Engine overheats	High-speed fuel mixture is too lean	Richen high-speed mixture
	Cooling air is being blocked	Get air to the head
	Excessive nitro in the fuel	Use fuel with lower nitro
	Excessive load on the engine	Check for binding in drive train
	Low-speed mixture too lean	Richen low-speed mixture
Engine hesitates or stumbles	High-speed mixture too lean	Richen high-speed mixture.
	Low-speed mixture too rich	Lean low-speed mixture.
	Engine overheated	Stop the engine and find the cause.
	Air bubbles in fuel line	Check for holes in fuel line.
	Glow plug fouled	Test or replace plug
Engine stalls instantly when throttle is fully opened from idle	Glow plug fouled	Replace glow plug.
	Low-speed mixture too lean	Richen low-speed mixture.
	High-speed mixture too rich	Lean high-speed mixture.
Engine stalls while driving around turns	Fuel level is low	Add fuel
	Idle speed set too low	Increase idle speed.

# AE .21 Engine Parts

## .21 Engine Assembly

Part no.	Description	Retail Price
25300	Complete Engine	\$249.99

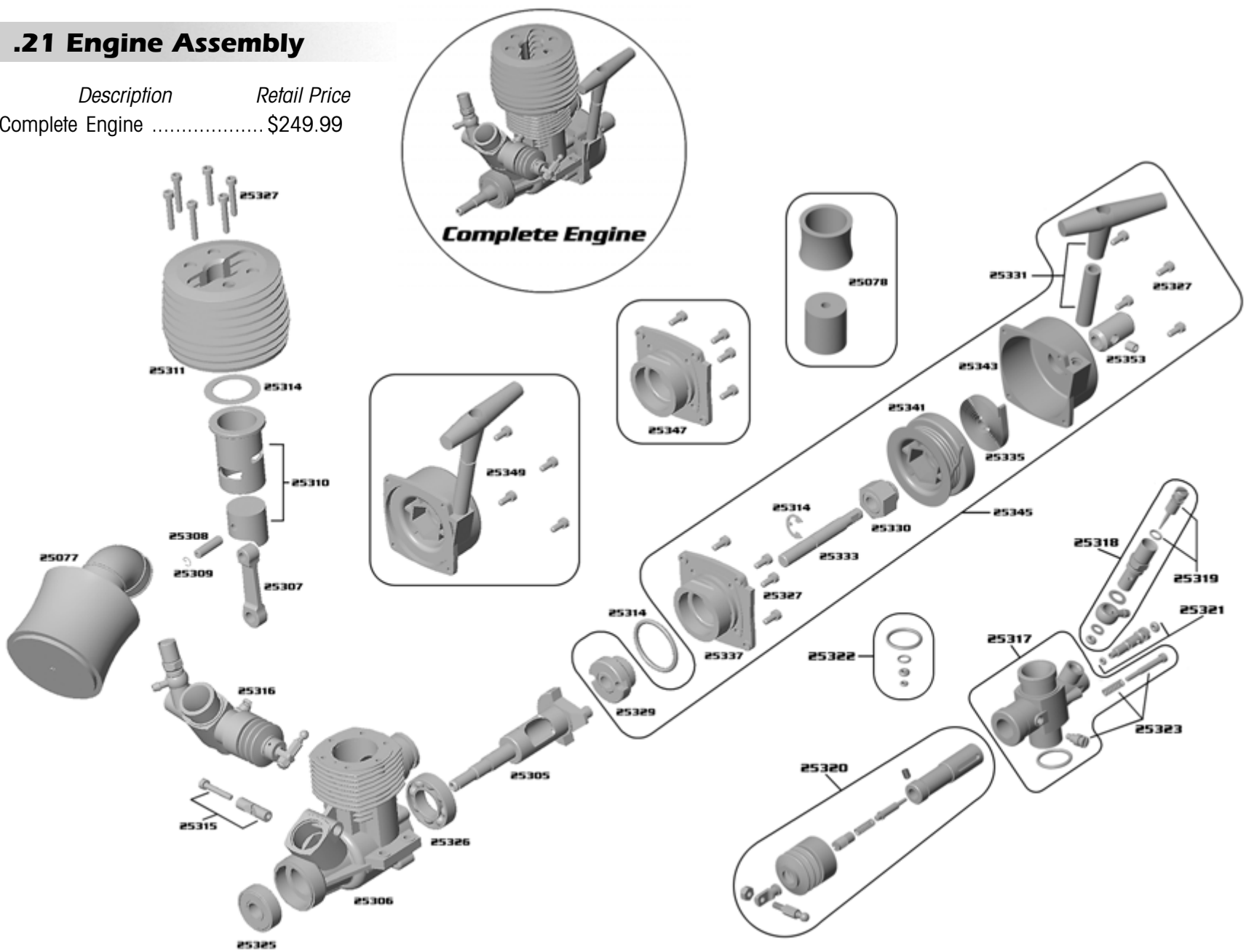

## .21 Engine Parts

Part no.	Description	Retail Price
MC59	McCoy Glow Plug	\$3.95
25305	Crankshaft	51.99
25306	Crankcase	52.99
25307	Connecting Rod	18.99
25308	Wrist Pin Assembly	4.99
25309	Circlip	2.99
25310	Cylinder & Piston	74.99
25311	Cylinder Head	44.99
25314	Gasket Set	3.99
25315	Carburetor Retaining Bolt	5.99
25316	Carburetor Assembly	59.99
25325	Ball Bearing, Front	10.99
25326	Ball Bearing, Rear	22.99
25327	Screw Set	6.99
25329	One Way Clutch Set	19.99
25330	One Way Clutch Set	17.99
25331	Handle Set	2.99
25333	Starting Axle	9.99
25335	Starting Spring	9.99
25337	Backplate	17.99
25339	Starting Wheel Wire	2.99
25341	Starting Wheel	4.99
25343	Starting Wheel Cover	13.99
25345	Starting Set	54.99
25347	Backplate & Screw Set	25.99
25349	Starting Wheel Cover Set	33.99
25353	Starter Coupling	7.99

## AE Monster GT .21 Carburetor Parts

Part no.	Description	Retail Price
25316	Complete Carburetor	\$59.99
25317	Carburetor Body	24.99
25318	Needle Valve Assembly	23.99
25319	Needle Valve Only	9.99
25320	Carburetor Slide Valve Assembly	28.99
25321	Mixture Metering Screw Set	9.99
25322	O Ring Set	4.99
25323	Bolt & Fuel Inlet	4.99
25324	Recovery Spring	2.50

## Accessories

Part no.	Description	Retail Price
1738	Factory Team Blue Glow Starter	\$29.99
25077	Air Filter Kit	7.99
25078	Foam PreFilter Element, 3 pack	9.99
3719	Nylon Ties, 6", 12 pack	2.00
7709	Nylon Ties, 4", 6 pack	1.25
7710	Foam PreFilter Treatment, 1 oz.	2.50

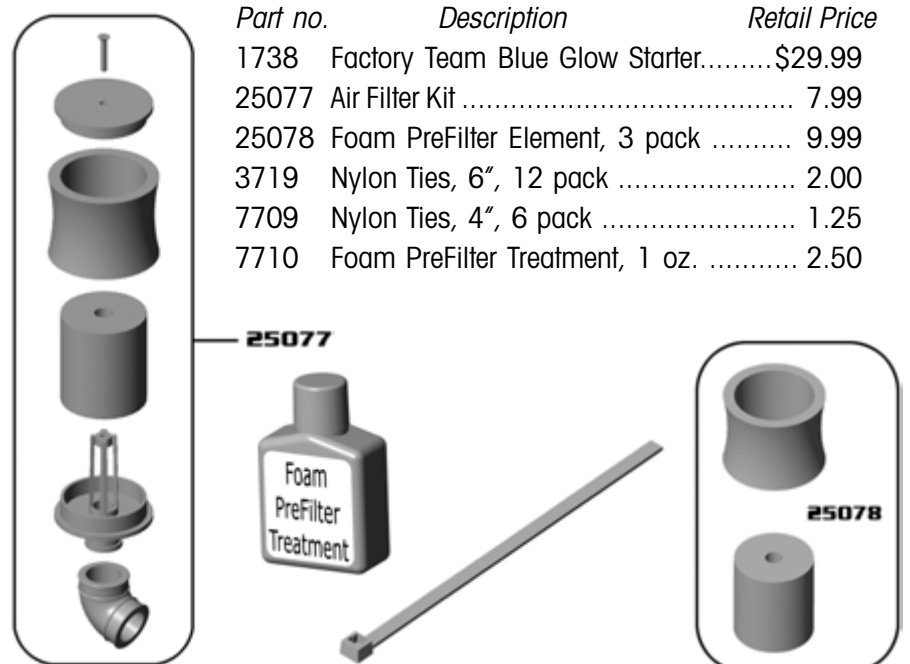

## Contact info

TEAM ASSOCIATED  
3585 Cadillac Ave.  
Costa Mesa, CA 92626



phone:  
fax:  
web site:

(714) 850-9342  
(714) 850-1744  
<http://www.rc10.com/>  
<http://www.TeamAssociated.com/>